

STG.NET "RPS-3" Remote Pump Switch Wiring Diagram

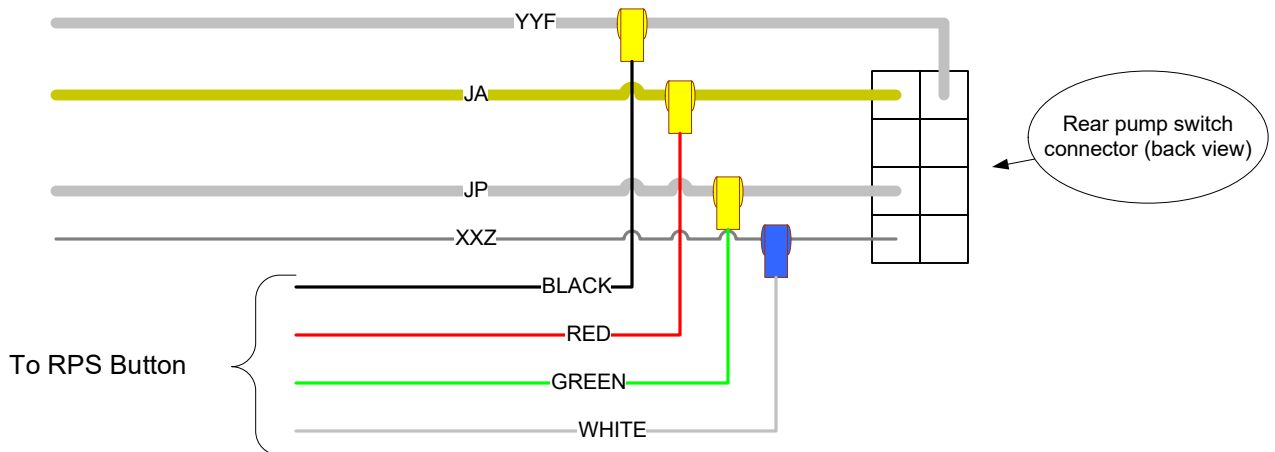
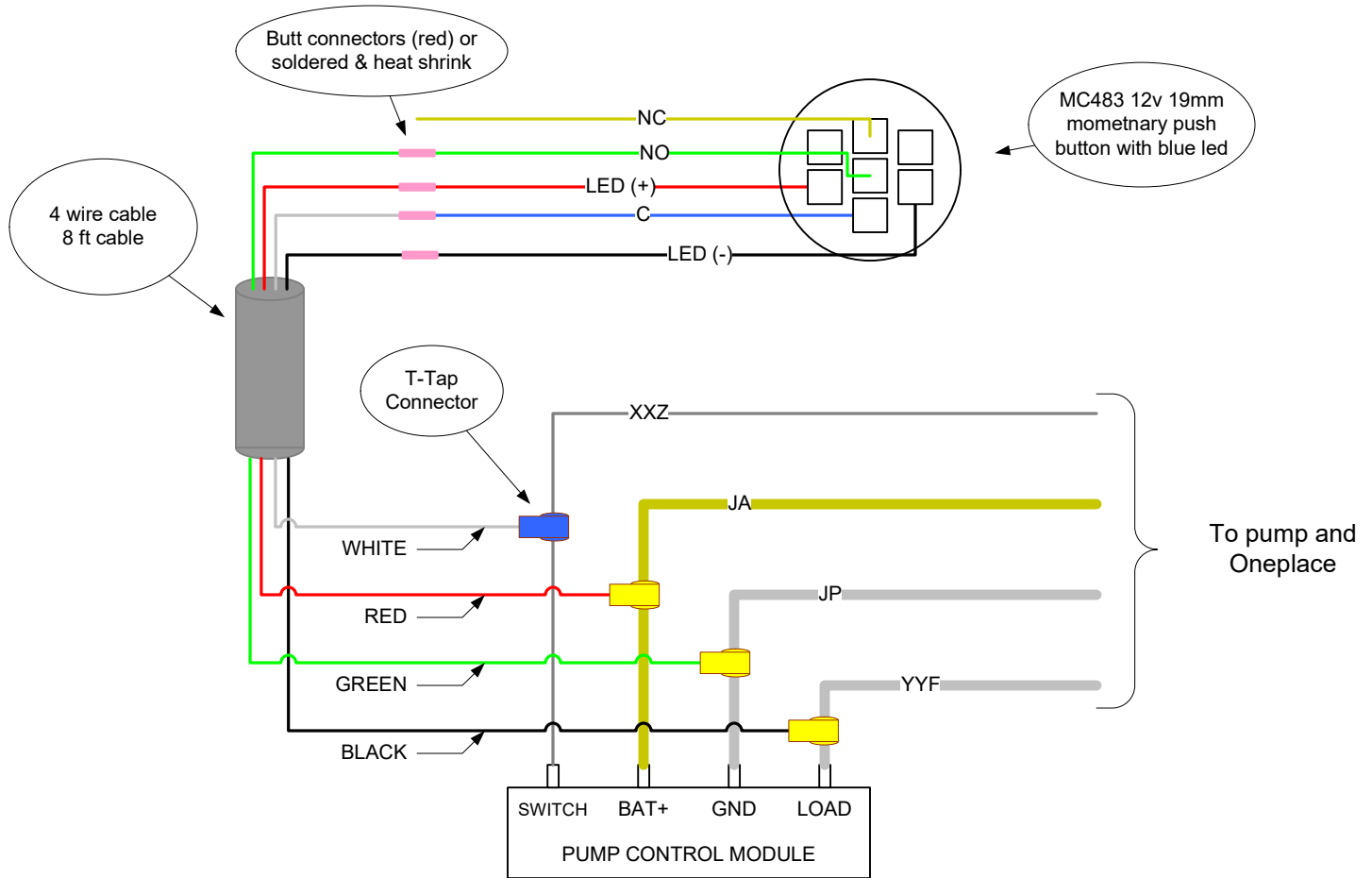

Installation Instructions:

- 1) Drill $\frac{3}{4}$ " hole in location desired for Switch Button and attach with nut or glue in place
- 2) Route cable from switch to location of pump control module or rear wall pump switch
- 3) Attach T-Taps to existing wires (yellow on thicker wires, blue to thinner wire)
- 4) Plug cables into correct T-Tap connectors by wire color (see diagram)
- 5) Test that button turns light on and off